

Osmio Zero Installation Reverse Osmosis System



User Manual Version 3 February 2020

Email: sales@reverseosmosisworld.co.uk

1	Safety Precautions	3
1.1	Power Safety Precautions	3
1.2	Setup Precautions	3
1.3	Usage Precautions	4
2	Product Description	5
2.1	Appearance Sketch Map	5
2.2	Display and Operation Interface	6
2.3	Product Specifications	7
3	Start Up	8
3.1	Introduction	8
3.2	Filling the Supply Pitcher	8
3.3	Power Connection	8
4	Use	9
4.1	Introduction	9
4.2	Flushing	9
4.3	Purification	9
4.4	Renew Water	9
4.5	Dispensing Water	10
4.6	Sleeping State	10
4.7	Power Off	10
5	Filter Maintenance	11
5.1	Introduction	11
5.2	Filter Replacement	11
5.2.1	Replacing the Pre Filter	11
5.2.2	Replacement of the carbon, reverse osmosis and post filters	12
5.2.3	Resetting the system after filter change	14
5.2.4	Sanitisation and Descaling	14
5.3	Failure State	15
5.3.1	Purification exception (Four Flashing Lights)	15
5.3.2	Burning alarm	15

Contents

6	Common Usage Problem	16
7	Quality Assurance	18
7.1	Preparing the System for Shipping	19
7.2	Going on Holiday	19
8	After-Sale Service	20
9	Electrical Schematic Diagram	20

1 Safety Precautions

1.1 Power Safety Precautions

- The system should be plugged into a normal UK 3 pin plug at your home or workplace and not be used in addition to AC 220-240V, 220V.
- Should be used in a grounding socket with rated current above 10A.
- Should only be used on an electrical circuit with RCD.
- Please do not use this product if the power cord or plug is damaged or when the plug is loose.
- If there is dust or water and other foreign matter on the power plug, please wipe it clean before use.

1.2 Setup Precautions

- The system should not be installed near heating equipment, electric heating products or other high-temperature places.
- The system should not be installed in a place of possible leakage of combustible gases or near any flammable substances.
- The system should only be used indoors and positioned on a stable flat surface avoiding direct sunlight and moisture.



Take Note: Boiling water is potentially dangerous.
It is the responsibility of the owner to take sensible precautions when operating the boiling water function of the system and to instruct other family members and other new users to operate it safely.

KEEP OUT OF REACH OF CHILDREN

1.3 Usage Precautions

TELL EVERYONE THAT USES THIS SYSTEM THAT THEY MUST EMPTY THE WATER OUT EVERY TIME THE SUPPLY TANK IS REFILLED, OR THE FILTERS CAN BLOCK

- On first use or if the unit has been idle for more than 2 days, run a complete cycle and discard the first batch of water produced. Fill your supply tank with water and then allow the machine to run until it fills the internal tank. Dispense water to ensure the internal tank is flushed.
- Unknown liquids or foreign objects are prohibited.
- If there is any water leakage from the machine, please disconnect the power and contact the customer service centre. Please ensure the Supply Water Tank and the filters have been inserted correctly and fully into the system.
- If there is any abnormal sound, smell, or smoke, etc., please disconnect the power and contact the customer service centre.
- Do not disassemble or modify the system without professional guidance, please contact the customer service centre if you need support.
- Do not move this product when it is in use.
- Do not use any detergent or alcohol based cleaner to clean the product, please wipe the machine with a soft dry cloth.
- Do not grasp the water nozzle or the knob to move the machine.
- This product cannot be used by people who are physically or mentally disabled or children unless supervised. Please keep it out of reach of children.

The filters on the system need to be changed every 6 months. We offer a 1 year warranty. If you have water hardness over 250 ppm Calcium Carbonate Hardness you may need to replace the carbon and membrane more frequently.

The system is designed to shut off if there is blockage in the membrane or prefilters. As the system recirculates the rejected water from the membrane, the TDS level of the water entering the membrane filter continually rises. Therefore, for those with water of higher TDS, more frequent membrane changes are required.

IMPORTANT NOTE: You must empty the Supply Tank before refilling it with fresh water as failure to do this can block your filters

2 Product Description

2.1 Appearance

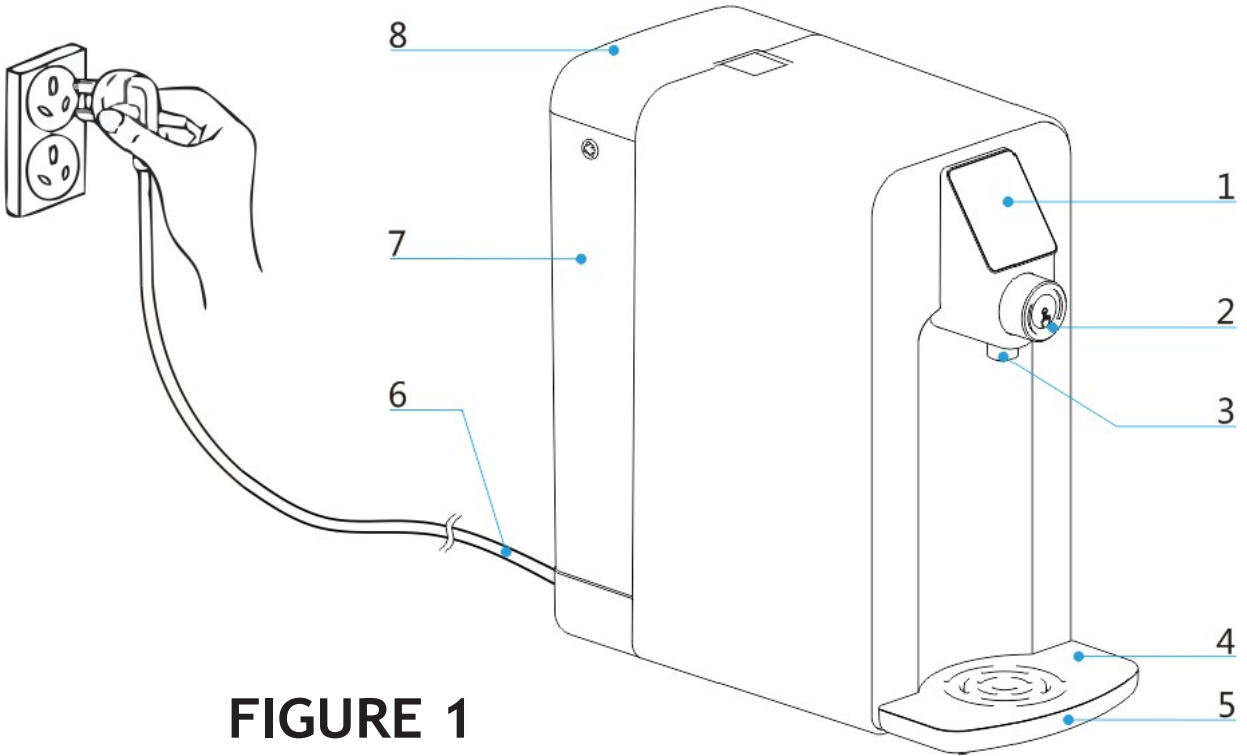

FIGURE 1

1 Display Panel

2 Control Button (Rotate & Press)

3 Nozzle

4 Drip Tray Cover

5 Drip Tray

6 Power Plug

7 Supply Tank

8 Supply Tank Lid

2.2 Display and Operation Interface

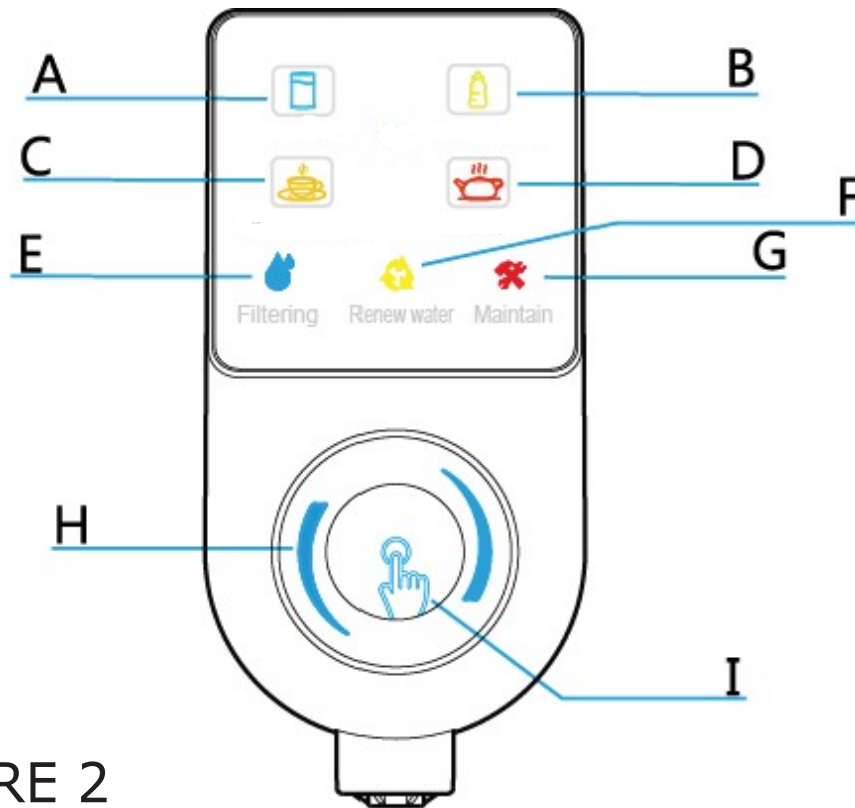

FIGURE 2

- A. Normal Water
- B. Warm Water (40°C-50°C)
- C. Hot Water (80°C-88°C)
- D. Boiled Water (90°C-98°C)
- E. Filtering Water
- F. Renew Water
- G. Filter Maintenance
- H. Rotate (Choose the Water Temp)
- I. Press to Get Water

2.3 Product Specifications

Electrical Properties

Rated Voltage : 220 - 240 V

Rated Frequency : 50 Hz

Rated Power: 2200W-2600W

Heating System

Rated Heating Power: 2180W-2580W

Hot Water Capacity: 30 l/h ($\geq 90^{\circ}\text{C}$)

Filter Stages

- 1 - Quick-Change Sediment Filter 5 μm : removes coarse particles, e.g. Sand, rust, chlorine, lime
- 2 - Quick-Change activated carbon filter: removes chlorine and organic impurities
- 3 - Quick-Change Membrane 50GPD: removes all pollutants and flavours to almost 100%
- 4 - Quick-Change Insertion Filter: Hygiene post filter, antibacterial, removes 99% of the bacteria and viruses and improves the taste.

Volume

Supply Pitcher 5 litres

Pure Water Tank 1.5 litres

Dimensions:

405mm Length (Depth)

183mm Wide

388mm Height

Weight': 7.1 kg

3 Start Up

3.1 Introduction

- Please place the system in a cool, ventilated, solid horizontal surface, away from any heat source. The system comes ready installed with the filters so you can fill the Supply Tank right away.

3.2 Filling the Supply Tank

- Open the tank lid (Figure 3).
- Lift the Supply Tank out.
- Fill the Supply Tank with fresh water and put it back on to the base (Figure 4) and close the lid. If you find it too heavy to lift, consider using a jug to do a bit at a time.
- Note: machine will not run without the Supply Tank Lid clipped on.

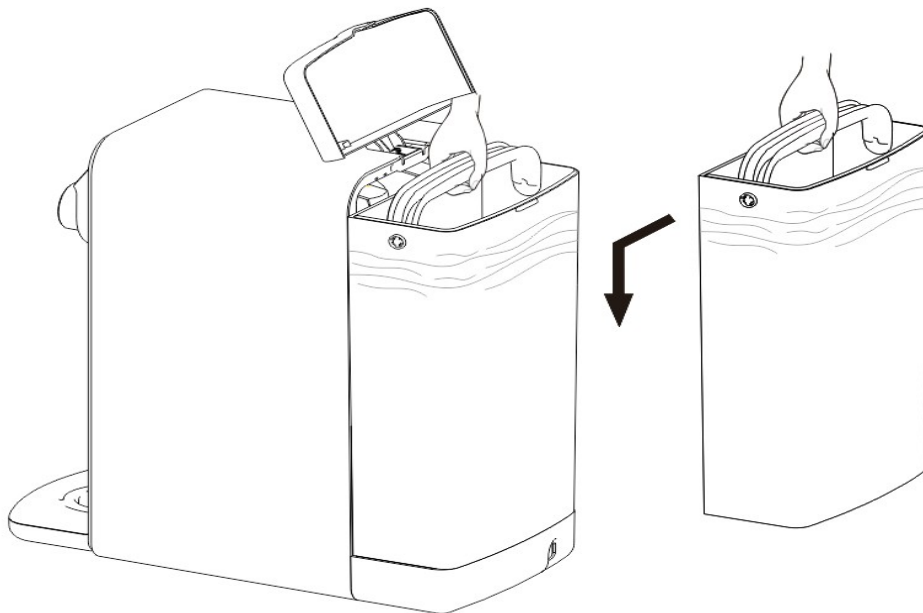
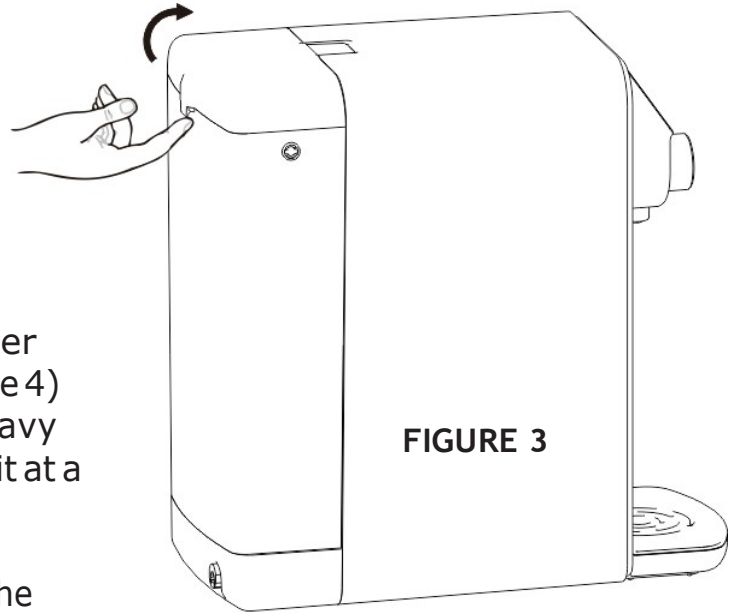

FIGURE 4

3.3 Power Connection

- Insert the power plug into the socket (see Figure 1). The system will beep and light up which indicates the machine is ready to use.
Note: This product is only suitable for AC 220-240V, 220V power supply, and should be used alone or over rated 10A with a earthed socket.

4 Usage

4.1 Introduction

- At first, produce and dispense 5 litres of water which you then dispose of by dispensing all the cold water. This will flush out any loose filter media. It is normal to see black water when using new filters.
- If there is water leakage from the machine, please disconnect the power and contact the customer service centre. If there is any abnormal or unexpected sound, smell, or smoke, etc., please disconnect the power and contact the customer service centre.
- If you live in a hard water area with over 280 ppm CaCO₃ then we recommend that you fill your supply tank with 3 litres of water not 5 litres.

4.2 Flushing

- After the setup, the machine automatically enters the flushing state and works for 120 seconds. In the flushing state, the filtering symbol of the display interface light will be on (see Figure 2) .

4.3 Purification

- After flushing, the machine automatically enters the filtering state. The filtering symbol on the display interface light will be on (see Figure 2).

4.4 Replace Water

- The system will detect the source water quality in normal operation. If the water level is lower than the set level, the user will be prompted to replace the source water. You must empty the Supply Tank every time it is refilled. The renew water symbol of the display interface will light up at this time (see Figure 2).

IMPORTANT NOTE: You must empty the Supply Tank before refilling it with fresh water as failure to do this can block your

4.5 Dispense Water

- Place the water container on the tray (see Figure 1). Rotate the knob to select the desired water temperature (Figure 5), and then click on (or push on for 3 seconds) the middle part of the knob (see Figure 6) to dispense one cup (or bottle) of water. Click the knob again if you want to stop getting water. Note: the system will automatically stop water after 30 seconds if you do not click the knob and will automatically stop after 60 seconds if you hold the button for 3 seconds.

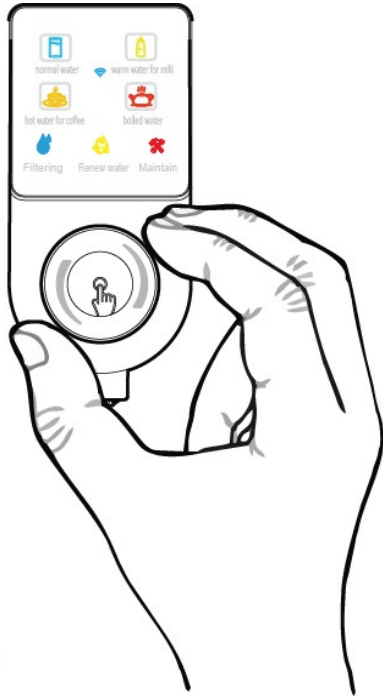

FIGURE 5

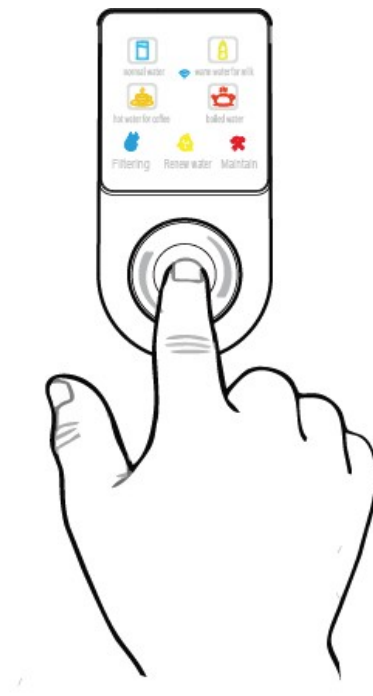

FIGURE 6

4.6 Sleeping state

- The system will automatically enter sleeping state when it is idle for more than 1 hour. If there is any knob or button operation, it will immediately return to service and then flush for 20 seconds.

4.7 Power off

- The system will automatically power off if the machine stays in sleeping mode for 1 hour. If there is any knob or button operation, it will power on automatically.

5 Filter maintenance

5.1 Introduction

First skip to section 5.2.4 to read about sanitisation and descaling (if you live in a hard water area) then come back to this section.

Use the company's certified filters. Disconnect the power. Do not disassemble or attempt to modify this product.

5.2 Filter replacement

5.2.1 Replacing the Pre Filter

- The pre-filter (PP) screwed in inside the supply tank should be changed every 6 months, or when needed (e.g. if blocked by poor source water).

STEP 1 Open the lid of the supply tank and wait for 5 seconds

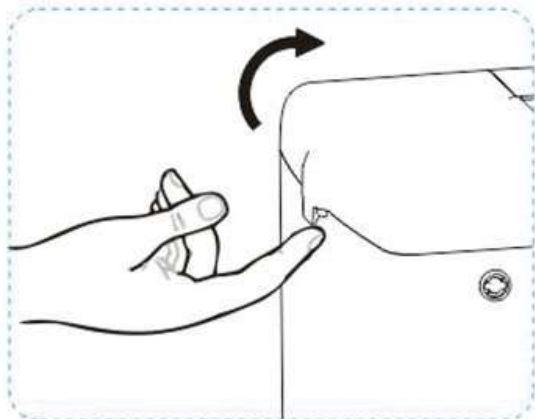

STEP 2 Lift the supply tank vertically up and out out keeping it flat

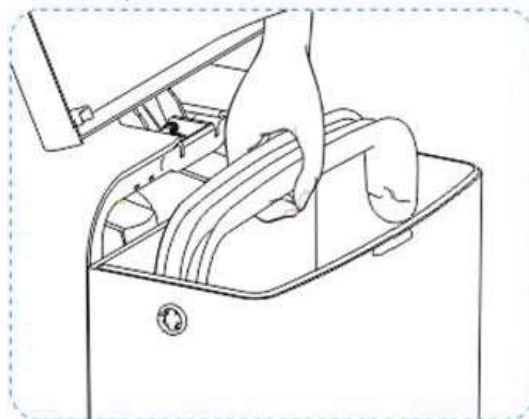

STEP 3 Unscrew the used pre filter and screw in the new one

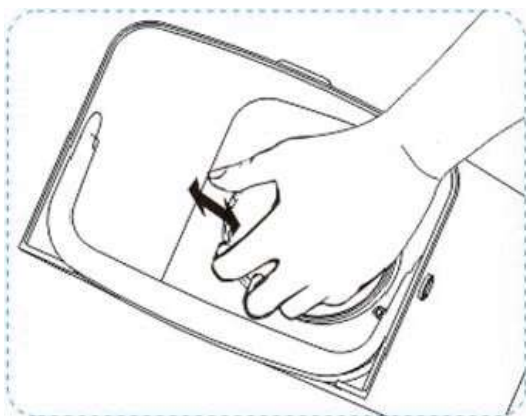

STEP 4 Swivel the filter to align the current month number to the replacement mark indicator

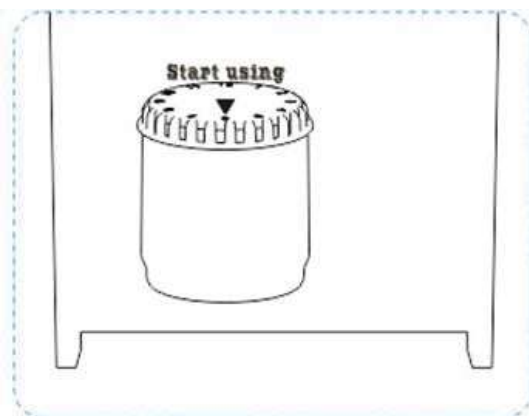

5.2.2 Replacement of the carbon filter, reverse osmosis filter and post filter

- These filters need to be changed every 6 months or when the red maintenance light comes on, whichever comes first. Turn the power off and replace the filters by following the steps below.

STEP 1 Open the lid of the supply tank and wait 5 seconds

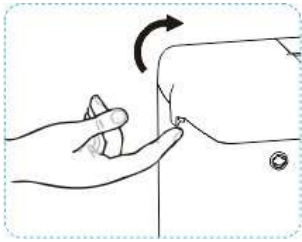

STEP 2 Lift the supply tank up and out vertically, keeping it flat

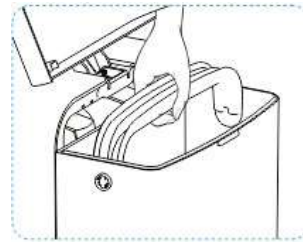

STEP 3 Starting at the base of the filter, tilt the filter towards you slightly and rotate the Carbon Filter and Membrane filter clockwise and remove them from the head.

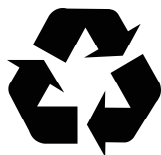
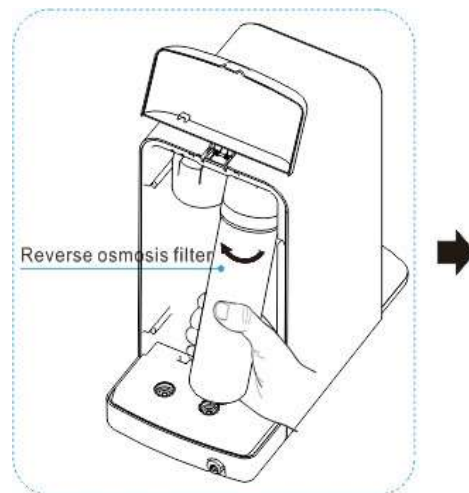
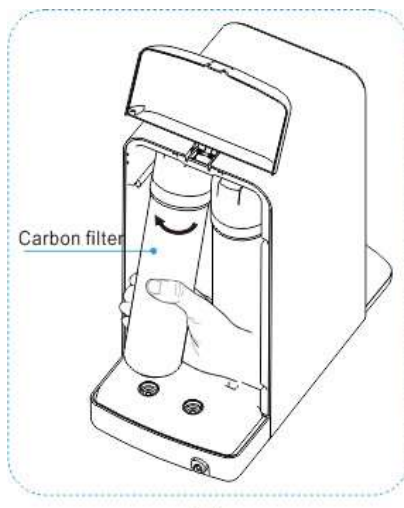

Help your environment and put all used filters
in recycled plastic waste

STEP 4 Pull out the Post Filter slowly with your finger and insert a new one fully.

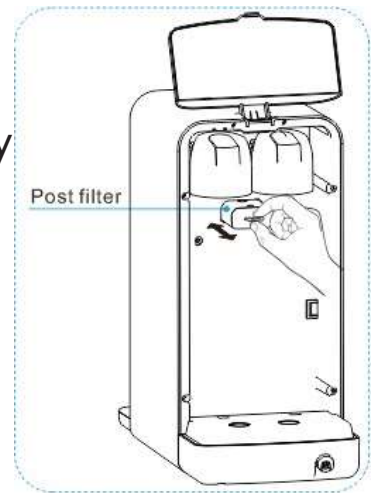

STEP 5 Start with the new Carbon Filters so the label is on the left hand side twist the filter on anticlockwise. Repeat the same with the Membrane Filter.

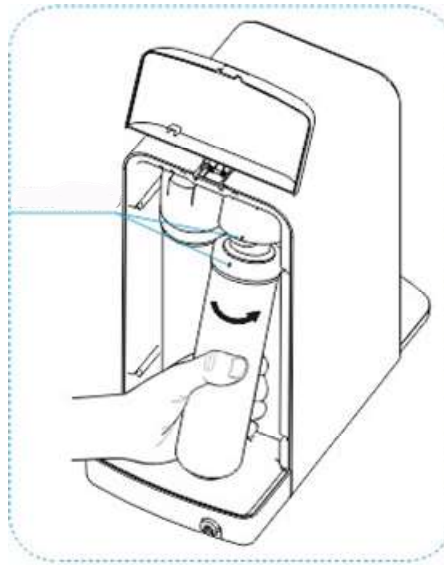
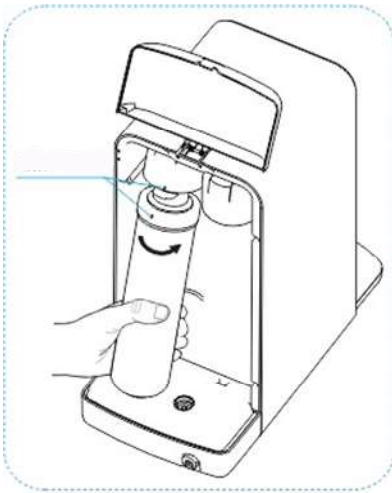

STEP 6 Fill the Supply Tank and place on the base and close the lid.

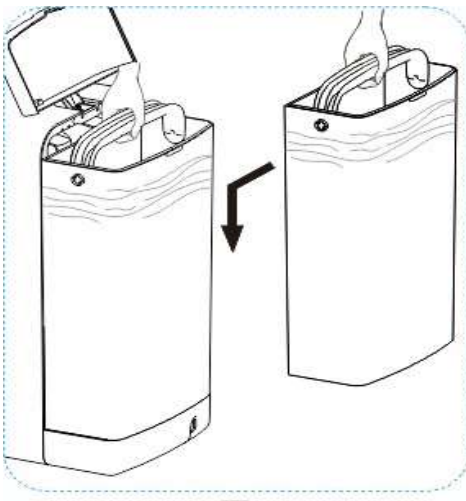

STEP 7 Press and hold the button and at the same time connect the power plug to the socket. (the system will make a beep sound). Now perform a full system reset - 5.2.3.

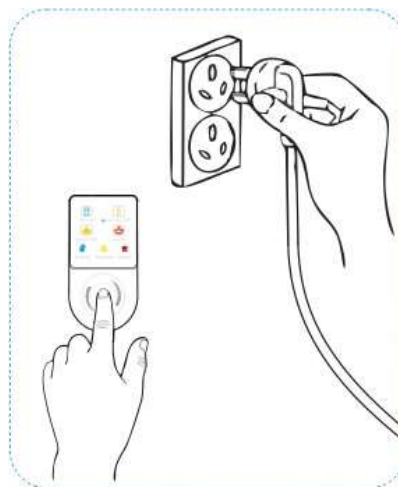

5.2.3 Resetting the system after filter change

- 1) Disconnect the system from power supply
- 2) Lift up the rear tank cover
- 3) Press and hold the water dispensing button with one hand while connecting the unit to a power supply, keep holding the button until you hear 4 beeps
- 4) Disconnect the system again from the power supply
- 5) Close the rear tank cover
- 6) Open the rear tank cover again
- 7) Connect the unit to a power supply
- 8) Close the rear tank cover

If properly done, maintenance light should disappear and the system goes to normal filtering mode.

5.2.4 Sanitisation and Descaling

We suggest sanitising the system every 6 months prior to the filter change and descaling the system every 3 - 4 months if you live in a hard water area. Contact your dealer to order the Osmio Zero Sanitisation Kit.

- 1) Lift the supply tank lid, then press the button repeatedly to dispense all the water out of the internal RO storage tank.
- 2) Remove all 4 filters (the Sediment in the supply tank, Carbon Block, RO Membrane and the PostRemineralisation Filter). Insert the three blank filters from the sanitisation kit in their place.
- 3) Fill the supply tank with 2.5 litres of water (do not put more in) and place it back on, add two Milton tablets when sanitising the system (or one tablespoon of citric acid when descaling), then wait for 5 minutes until dissolved.
- 4) Close the supply tank lid, this will refill the internal RO storage tank with Milton solution (or descaling solution), wait until the pump stops and the filtering light goes out. When the Replace Water light comes on and there is still over 2cm of water in the supply tank, open and close the Supply Tank Lid to enable the water level in the Supply Tank to drop to approximately 2cm level. Then dispense 300 ml of water.

- 5) Wait until for 15 - 30 minutes for the Milton solution (or descaling solution) to sterilise (descale) all parts of the Osmio Zero system.
- 6) Lift the supply tank lid, then press the button repeatedly to dispense all the water/Milton solution (descaling solution) until no more can be dispensed from internal RO storage tank
- 7) Remove supply tank and rinse well. Fit a new sediment filter in the supply tank (or refit existing one if mid term). Leave the other sanitisation filters in place. Refill the tank with clean water to 2.5 litres and allow the system to flush this completely, so keep doing a long press and waiting for the filtering to stop. Repeat this process four times (4 x 2.5 litres of water).
- 8) Remove all 3 blank filters and then refer back to section 5.1. for new filter change process or replace your original filters if performing an interim sanitisation (descaling) e.g 3 - 4 monthly.
- 9) After sanitisation (descaling) the fastest way to clean all the sanitising (descaling) fluid from the internal tank is to lift the supply tank lid, then press the button repeatedly to dispense water until no more can be dispensed from the internal RO storage tank, then close the supply tank lid for the system to refill the internal RO tank. Repeat this step until no more sterilising solution (descaling solution) can be detected (usually 2 or 3 times).

5.3 Failure state

5.3.1 Purification exception (Four Flashing Lights)

The system will show the purification exception state if the machine purifies water for a long time and cannot stop, all the four temperature icons on the display will flash. The machine may make louder noises leading up to this. This happens when the Carbon Filter is blocked, and also the RO Membrane might be blocked. First change the carbon block and see if the production rate goes back to normal and if not, then also change the RO membrane. Perform a full system reset (see section 5.2.3). You will also need to change the Sediment Filter and Remineralisation Filter too if they are 6 months old.

5.3.2 Burning alarm

The system enters the dry state if the heater works without water or if the temperature exceeds the safe setting, the icon for hot water (80°C-88°C) will blink, the machine can only dispense normal temperature water but cannot dispense any kind of hot water. Solution: please contact our helpdesk.

Email: sales@reverseosmosisworld.co.uk

6 Common usage problems

If you have some problems during the usage, please check the problems by following the guide below.

Usage Problems	Likely Cause	Suggested Solution
Cannot dispense ambient temperature water	Power is disconnected. Not pressing on the right place.	Check if the power plug is loose or not in place. Press the button again.
	Water shortage in purified water tank, "filtering" icon blinking.	If the "renew water" icon is blinking in the display, empty the supply tank and refill and recheck
Cannot dispense hot water	Power has only just been connected and the system needs time to warm up	Dispense a little bit of the normal temp water first then wait for 15 minutes and then dispense hot water.
	The machine is in the state of "burn alarm".	Dispense ambient temperature water several times then retry dispensing hot water.
	Purified Water shortage "filtering" icon blinking.	Wait for moment until the "filtering" icon light is on all the time then dispense hot water.
Machine does not filter	Supply Tank lid not fully closed	Push the lid of supply tank onto the tank properly.
	Water level in the Supply Tank is lower than setting level line and "renew water" icon is blinking.	Pour out the water and refill with fresh water to the 5 litre line. Allow the system to begin filtering.
	Supply Tank has not been correctly installed in place.	Put the Supply Pitcher tank in place correctly.

Usage Problems	Likely Cause	Suggested Solution
Abnormal sound during the filtering.	Water level in the Supply Tank is too low.	Remove any water in the Supply Tank and refill to the 5 litre level and try again.
	Air blocked in the water system.	Open and close the lid of source water tank several times to try to flush air from the system.
	Filters are blocked and need replacement.	Change the RO Membrane Filter first and if this does not solve the problem then do a complete filter change. If the system was run in this state permanent damage can be made to the pump.
Water leakage.	Drip Tray is full of water.	Empty the tray.
	Foreign matter stuck in the one way valve of the Supply Pitcher base.	Clean the one way valve
	Foreign matter stuck on the seal spacer of the Supply Pitcher.	Clean the seal spacer
	Internal water leakage.	Power off and empty the Supply Pitcher and contact customer service.
Odour in the water	Brand new system	Dispense 5 litres of water before using the system.
	Unused for more than 5 days	Dispense 5 litres of water before using the system.
	Filters over 6 months old	Change all the filters

7 Quality assurance

The warranty is valid for the UK and Republic of Ireland as well as the following EU countries: Austria, Belgium, Czech republic, Denmark, France, Germany, Netherlands, Luxemburg, Slovakia, Slovenia, Spain, Italy, and Hungary.

The warranty becomes effective at the date of purchase or at the date of delivery if this is later. Proof of purchase is required under the terms of the warranty. The warranty provides benefits in addition to your statutory consumer rights.

Our 3 Year Warranty covers the repair or replacement of all or part of your system if your system is found to be defective due to faulty materials or manufacture within 3 years of purchase. We also offer free returns for customers in mainland UK. Customers from Ireland and the EU countries listed above can also take advantage of this service but they are required to ship the system to us (no free returns).

If any part is no longer available, or out of manufacture, Osmio reserve the right to replace it with a suitable alternative.

Do not disassemble the system yourself as this will void your warranty and the company will not assume any responsibility for the resulting quality problems or accidents.

The system is BPA-free and made to top manufacturing specifications and is CE certified.

The company will charge fully for parts and maintenance if it exceeds the warranty period or the machine breaks down due to damage. Please keep your sales invoice as proof of purchase.

Osmio does not guarantee the repair or replacement of a product that has failed for any of the following reasons:

- Faulty installation, repairs or alterations not in accordance with the installation guide.
- Normal wear and tear. We suggest the system should be replaced after 5 years.
- Accidental damage or faults caused by negligent use or care; misuse; neglect; careless operation and failure to use the system in accordance with the operating guidelines.
- Failure to maintain the water filters in accordance with the instructions.
- The use of anything other than genuine Osmio replacement parts, including the water filter cartridges.
- The use of the filter system for anything other than normal domestic household purposes.
- Failures of, or failures caused by, parts not supplied as part of the genuine Osmio system.

7.1 Preparing the system for shipment

1. Empty the supply tank
2. Remove the carbon, membrane and post filters
3. Turn off the machine at the switch, wait 5-10 seconds for all lights to go off
4. Turn the machine back on
5. Press the dispenser button for 3-5 seconds for a long press to begin
6. When the machine is empty, it will make a gurgling noise, if it does not do this after the first long press, repeat steps 3-5.
7. Once the Osmio Zero's internal tank is empty, lift the machine and turn it upside down (over a sink) and then back upright around 5 times. Each time you turn it upright, some water should leave the spout. Once no water leaves the system it is ready to be packed and shipped.
8. Before re-installing the filters, turn them upside down and shake any water from inside.
9. Re-install the filters and package the machine up, into its original box with foam supports. If you no longer have the original packaging, please pack the system in a reasonable sized box and ensure there is enough stuffing and packaging for the system to make it back to us safely. If unsure please contact our customer service email sales@reverseosmosisworld.co.uk

7.2 Going on holiday

If you are going away for more than 3 - 4 days follow these instructions

1. Empty the supply tank
2. Remove the carbon, membrane and post filter
3. Turn off the machine at the switch, wait 5-10 seconds for all lights to go off
4. Turn the machine back on
5. Press the dispenser button for 3-5 seconds for a long press to begin
6. When the machine is empty, it will make a gurgling noise, if it does not do this after the first long press, repeat steps 3-5.
7. Once the Osmio Zero's internal tank is empty, lift the machine and turn it upside down (over a sink) and then back upright around 5 times. Each time you turn it upright, some water should leave the spout. Once no water leaves the system it is ready to be packed and shipped.
8. Once no water leaves the system turn the filters upside down and shake any water from inside and then re-install the filters on the system
9. On return from holiday fill the supply tank, allow the system to filter and fill the internal tank, then dispense all water produced to flush the system. The system is now ready to use again.

8 After-sale service

Our product has 3 year warranty and an extended 5 year warranty can be purchased (for repair, replacement or compensation of faulty products). If the product you bought has any quality problems, please bring your invoice to the dealer's shop, or contact them online. A maintenance service will be offered within 5 years. Please read the previous page for our warranty policy for your country. Customer service email: sales@reverseosmosisworld.co.uk

9 Electrical & Schematic Diagram

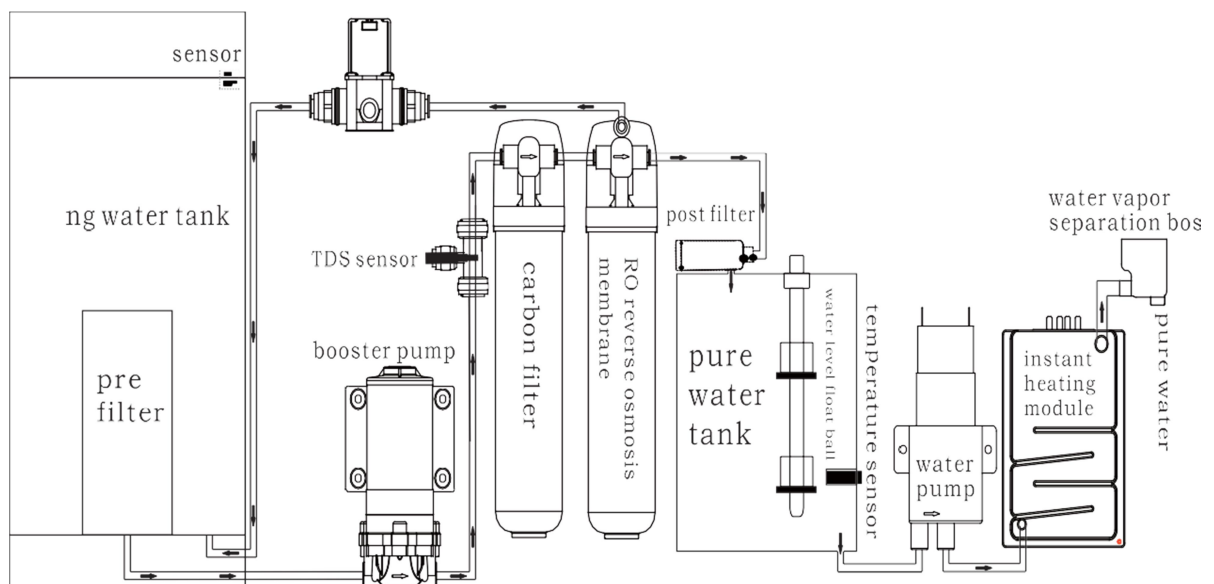
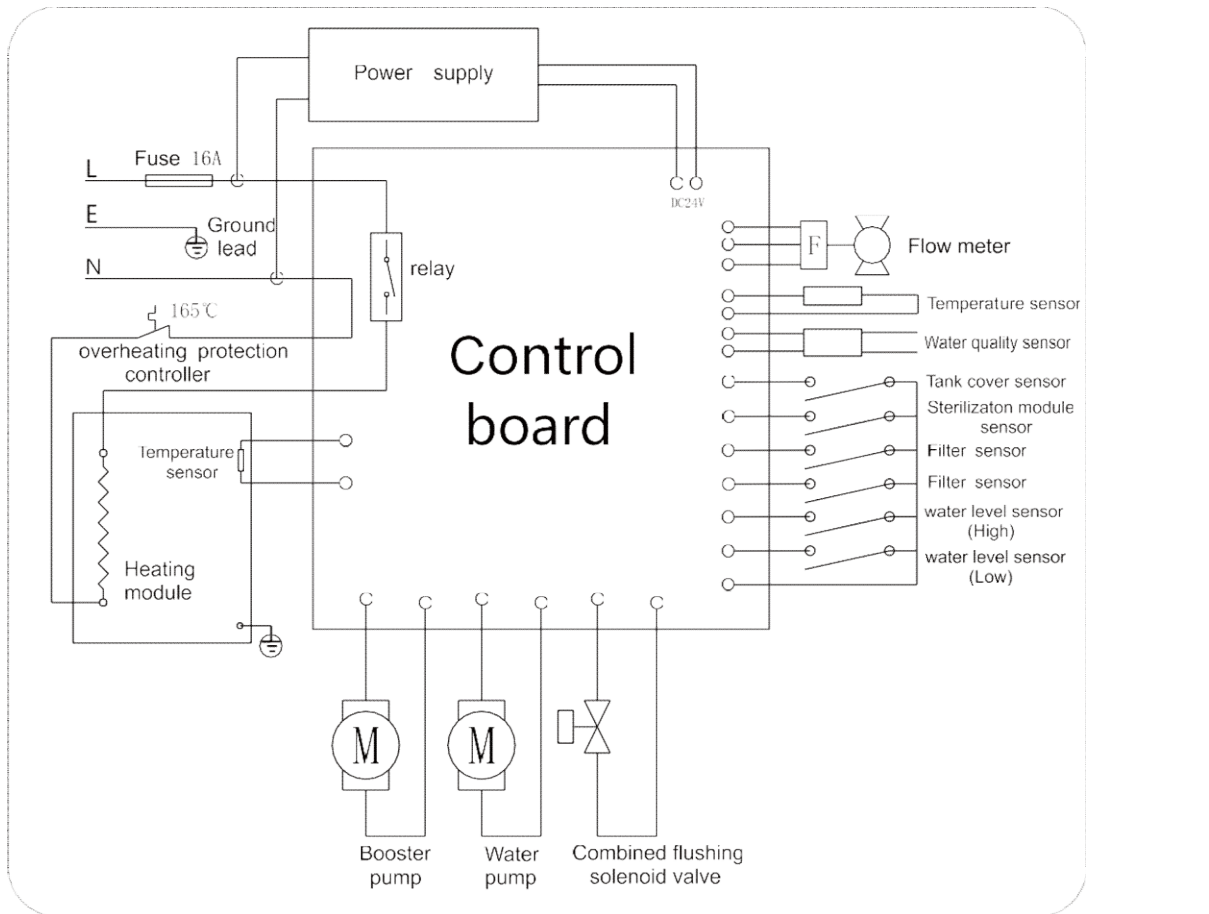

Declaration of conformity



This product may not be treated as household waste. Instead it shall be handed over to the applicable collection point for the recycling of electrical and electronic equipment. By ensuring this product is disposed of correctly, you will help prevent potential negative consequences for the environment and human health, which could otherwise be caused by inappropriate waste handling of this product.

For more detailed information about recycling of this product, please contact your local city office, your household waste disposal service or the shop where you purchased the product.

IEC 60335-2-15 Safety of household and similar electrical appliances. Part 2: Particular requirements for appliances for heating liquids:
Report Number..... STL/R 01601-BC164902

Certificate of Conformity for Quality Management System ISO9001: 2015 Standard in the scope of design and manufacturer of water purifiers.

NSF Testing Parameters and Standards

- 1) Determination of extractive residue, density and melting point for propylene homopolymer according to US FDA 21 CFR 177.1520
- 2) Determination of extractives residue according to US FDA 21 CFR 177.1850
- 3) Determination of extractive residue according to US FDA 21 CFR 177.2600
- 4) Determination of identification test, heavy metal(as Pb),lead and water extractables test refer to FCC standard